

# ROLL UP TRUCK BOX COVER SPECIAL TOOLBOX INSTRUCTIONS



## 19" TO 21" OVER THE RAIL TOOLBOXES

Read and follow these special instructions along with the standard instructions carefully before installing or using this cover.

**NOTICE TO INSTALLER:** Even if familiar with product, read special instructions prior to installation as improvements may be made without notice. Always handle components with care. When done, these special instructions must be given to the consumer.

**NOTICE TO CONSUMER:** Before using this product, read special instructions. Save these special instructions for future reference.

**NOTICE:** This cover fits most truck boxes with a 19" to 21" over the rail toolbox.

# PREPARATION

**IMPORTANT:** Toolbox cover may impede latch operation on some low profile toolboxes. Toolbox latches need to be located above bed caps so opening of toolbox is not impeded.

## TOOLS NEEDED

- 1/2" Wrench
- Protective eyewear
- Tape measure or ruler

**NOTE:** These special instructions are to be used for 19" to 21" over the rail toolboxes only. If toolbox is already installed, measure its location. If not installed per measurements in Step 1, it will need to be relocated.

**NOTE:** For best seal adhesion, ensure air and surface temperature is above 60° F.

**▲ CAUTION:** Over tightening hardware may damage components.

# 1: PLACING TOOLBOX

A. Clean surface of bulkhead with provided alcohol pad. Peel backing from weather seal and adhere  $1/16'' - 1/8''$  above edge of bed cap on upper inside edge of bulkhead. Position toolbox against inside edge of box bulkhead while compressing weather seal.

**IMPORTANT:** Save alcohol pad for use in Step 3.

**NOTE:** If gap is too large for weather seal, use alternative filler materials (not supplied in kit).

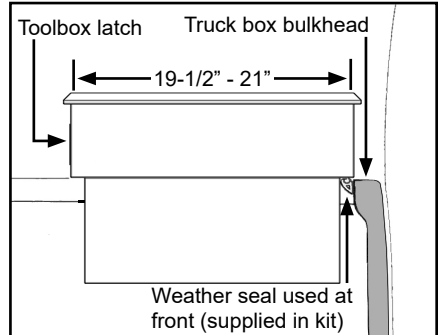
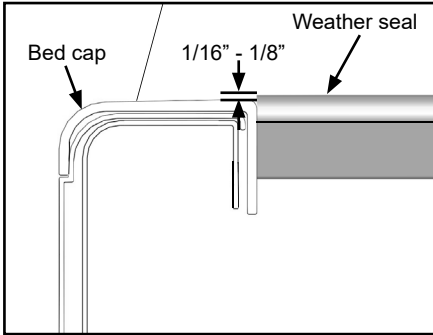

**NOTE:** For 19 -  $19-1/2''$  toolboxes, see image for proper toolbox placement.

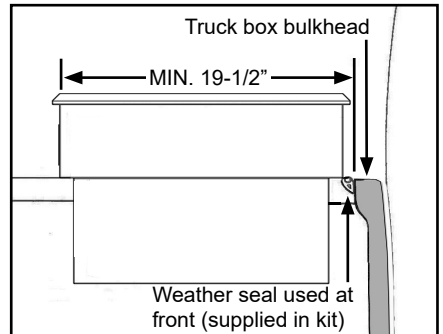

B. Align header bar flush with top of truck box, push tight against toolbox wall and apply enough pressure to compress weather seal against toolbox wall. Hold and secure tight with clamps.

**NOTE:** Use (2) clamps to install header bar, (1) clamp at each end (save remaining clamps for cover).

**NOTE:** If unable to clamp header bar due to truck box structure, see special bolt on header bar instructions.

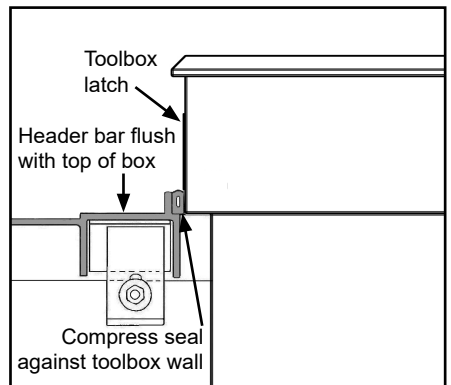

## 2: INSTALLING SIDE RAILS

A. Depending on toolbox length, perform one of the following:

- **For 19" Toolbox:** Position side rails with 1/2" clearance from inside of tailgate.
- **For 20" to 21" Toolbox:** Position side rails with 1/4" clearance from inside of tailgate.

B. Allow front edge of side rail to butt up against header bar or, if needed, to overlap on top of header bar. Refer to standard instructions for rail and clamp adjustments. Then clamp side rail in place.

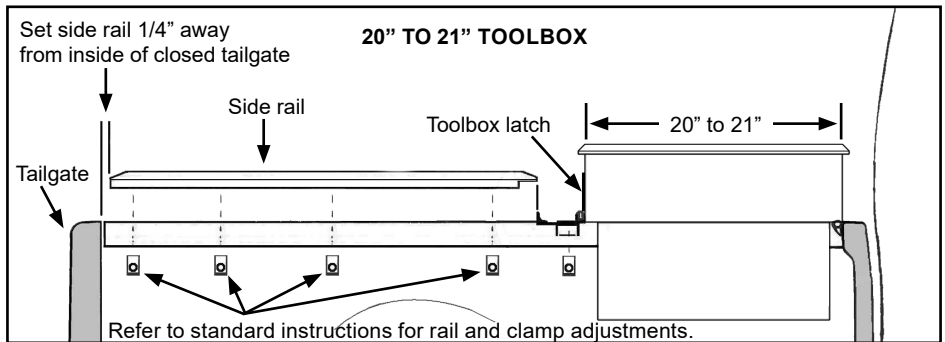
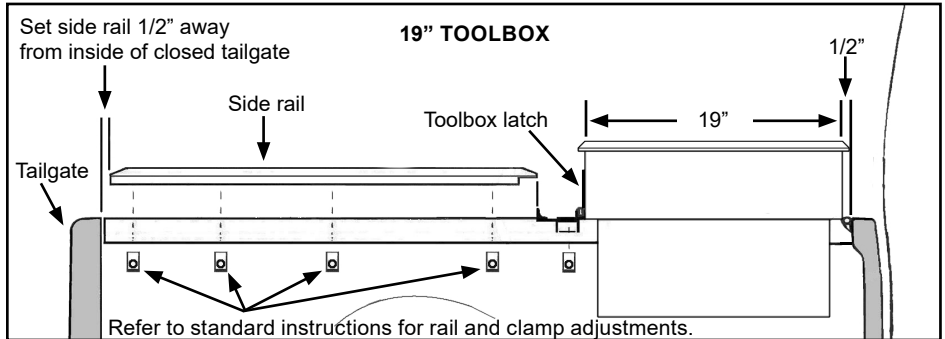

## 3: INSTALLING "L" WEATHER SEAL

A. At header bar, clean top surface with provided alcohol pad. Peel backing from "L" weather seal and adhere to the top of header bar and front of side rails. Ensure weather seal spans the length of the header bar.

**Tip:** For best protection, use silicone seal at front of side rail and header bar along side of box (not supplied in kit).

B. For remaining cover installation, refer to standard instructions.

